

1106D-E70TAG2

1100

135 kWm (Gross) @ 1500 rpm

155 kWm (Gross) @ 1800 rpm

ElectropaK

Series

Basic technical data

Number of cylinders	6
Cylinder arrangement	In-line
Cycle	4 stroke
Induction system	Turbocharged and air charge cooled
Combustion system	Direct injection diesel
Compression ratio	16.8 : 1
Bore	105 mm
Stroke	135 mm
Cubic capacity	7.01 litres
Direction of rotation	Anticlockwise when viewed from flywheel
Firing order	1, 5, 3, 6, 2, 4
Estimated total weight (dry)	788 kg
Estimated total weight (wet)	822 kg

Overall dimensions (ElectropaK)

Height	1142 mm
Length (air cleaner fitted)	1763 mm
Width	788 mm

Moments of inertia

Engine rotational components	0.27 kgm ²
Flywheel	1.26(SAE2) kgm ²

General installation

Centre of gravity, ElectropaK

Forward from rear of block (wet)	476 mm
Above crankshaft centre line (wet)	176 mm
Offset to RHS of crankshaft centre line (wet)	-16 mm

Performance

Speed variation at constant load	± 0.18%
Cyclic irregularity at standby power	0.003
All ratings within	± 3%

Note: All data based on operation to ISO 3046-1:2002 standard reference conditions.

Sound level

Average sound pressure level for standby power @ 1 m... TBC

Test conditions

Air temperature	25°C
Barometric pressure	100 kPa
Relative humidity	44%
Air inlet restriction at maximum power	- 5 kPa (maximum)
Exhaust back pressure at maximum power	15 kPa (maximum)
Fuel temperature	40°C

If the engine is to operate in ambient conditions other than those of the test conditions, suitable adjustments must be made for these changes. For full details, contact Perkins Technical Service Department.

General Installation	Units	50 Hz (1500 rpm)		60 Hz (1800 rpm)	
		Prime	Standby	Prime	Standby
Gross engine power	kW	135.9	149.7	155.6	171
Brake mean effective pressure	kPa	1549.7	1707.9	1478.1	1626.2
Mean piston speed	m/s	6.7		8.1	
ElectropaK nett engine power	kW	129.0	142.9	145.4	161
Engine coolant flow (against 35 kPa restriction)	litres/min	142		170	
Combustion air flow (at STP)	m ³ /min	10.6	11.0	13.9	14.4
Exhaust gas flow (maximum)	m ³ /min	24.00	25.00	28.77	29.93
Exhaust gas temperature (maximum) in manifold (after turbocharger)	°C	513		450	
Nett engine thermal efficiency	%	36.6	37.4	38.9	39.4
Typical genset electrical output (0.8pf 25°C)	kWe	114	126	135	143
	kVA	142	157	169	178
Regenerative power (estimated)	kW	11.5		13.2	
Assumed alternator efficiency	%	91	91	91	92
Energy balance					
Heat in fuel	kW	352.4	381.5	400.1	434.7
Power to cooling fan	kW	4	4	7	7
Power to coolant and lubricating oil	kW	64.0	72.5	69	74.9
Power to residual losses (alternator)	kW	2.8	2.8	3.1	3.1
Power to exhaust	kW	107.5	114.1	119.5	128.3
Energy to charge coolers	kW	19.4	21.2	29.7	32.5
Power to radiation	kW	24.0	25.4	26.3	27.9

Prime power: Unlimited hours usage with an average load factor of 80% of the published prime power over each 24 hour period. A 10% overload is available for 1 hour in every 12 hours operation.

Standby power: Limited to 500 hours annual usage, with an average load factor of 80% of the published standby power rating over each 24 hour period. Up to 300 hours of annual usage may be run continuously. No overload is permitted on standby power.

Cooling system

Cooling pack

Overall weight (wet)	90 kg
Overall face area	564924 mm ²
Width	716 mm
Height	789 mm

Radiator

Face area	351,840 mm ²
Number of rows and materials	4 rows, Aluminium
Matrix density and material	10 fins per inch, Aluminium
Width of matrix	440 mm
Height of matrix	800 mm
Pressure cap setting (minimum)	100 kPa

Charge cooler

Face area	203,483 mm ²
Number of rows and materials	2 rows, Aluminium
Matrix density and material	10 fins per inch, Aluminium
Width of matrix	220 mm
Height of matrix	789 mm

Fan

Diameter	610 mm
Drive ratio	1.25:1
Number of blades	7
Material	Nylon
Type	Pusher
Air flow @ 1800 rpm	5.76 kg/s
Power @ 1800 rpm	7 kW

Coolant

Total system capacity	21 litres
System drawdown capacity	10%
Engine capacity	9.5 litres
Maximum top tank temperature	108°C
Temperature rise across engine (maximum rating dependent)	12°C
Maximum permissible external system resistance	35 kPa
Thermostat operation range	82°C to 95°C
Shutdown switch setting	114°C
Coolant pump method of drive	Gear
Recommended coolant immersion heater rating (minimum)	0.75 kW
Recommended coolant	BS6580 - 1992, ASTM D3306 and ELC coolants to 1E1966

Duct allowance

Maximum additional restriction (duct allowance to cooling airflow and resultant minimum air flow) - Standby power

Description	rpm	kPa	kg/s
Duct allowance with inhibited coolant at 53°C			
Minimum air flow	1500	0.125	3.5
	1800	0.12	5.2
Duct allowance with inhibited coolant at 46°C			
Minimum air flow	1500	0.200	3.25
	1800	0.200	4.6

Electrical system

Alternator	8SI
Alternator voltage	12 volts
Alternator output	65 amps
Starter	AZF
Starter motor voltage	12 volts
Starter motor power	4.0 kW
Number of teeth on the flywheel	126
Pull-in current of starter motor solenoid @ 25°C maximum ⁽¹⁾	12 volts 68 amps
Hold-in current of starter motor solenoid @ 25°C maximum ⁽¹⁾	12 volts 20 amps
Engine stop method	CAN link signal or Hardwire input to engine ECM

¹ All leads to rated at 10 amps minimum

Cold start recommendations

Minimum required cranking speed over TDC

60 rpm

	5 to -5°C	-5 to -20°C	-20 to -25°C
Starter	AZF		
Battery	1 x 750CCA	2 x 750CCA	2 x 900CCA
Maximum breakaway current	NA		
Cranking current	1000A		
Aids	None	Glowplugs	
Minimum mean cranking speed	130 rpm	100 rpm	100 rpm

Note: Battery capacity is defined by the 20 hour rate

Note: If a change to a low viscosity oil is made, the cranking torque necessary at low ambient temperatures is much reduced. The starting equipment has been selected to take advantage of this. It is important to change to the appropriate multigrade oil in anticipation of operating in low ambient temperatures

Exhaust system

Maximum back pressure - 1500 rpm & 1800 rpm	15 kPa
Exhaust outlet, internal diameter	115.9 mm

Fuel system

Injection components

Injector Electronic CRIN2
 Fuel pump CB28

Fuel priming

Priming pump type Manual
 Maximum priming time 180 seconds

Fuel feed

Maximum fuel flow 6.6 litres/min
 Maximum suction head at engine fuel pump inlet -17 kPa
 Maximum static pressure head 10 kPa
 Fuel temperature at engine fuel pump inlet 75°C
 Tolerance on fuel consumption ± 5%

Fuel specification

Fuel standard Various (contact Perkins Technical Department)

Fuel consumption

Load	Type of operation and application			
	1500 rpm		1800 rpm	
	g/kWh	litres/hr	g/kWh	litres/hr
110% Prime power	212.6	38.0	212.1	43.1
100% Prime power	216.5	35.1	214.6	39.7
75% Prime power	229.6	27.9	231.4	32.1
50% Prime power	234.1	19.0	240.3	22.2
25% Prime power	249.6	10.2	263.9	12.2

Induction system

Maximum air intake restriction

Clean filter 4 kPa
 Dirty filter 8 kPa
 Air filter type paper element

Lubrication system

Maximum total system oil capacity 17.5 litres
 Minimum oil capacity in sump 12.5 litres
 Maximum oil capacity in sump 15.5 litres
 Maximum engine operating angles -
 Front up, front down, right side, left side 7°
 Sump drain plug tapping size 3/4 - 16 UNF
 Shutdown switch setting (where fitted)
 Oil pressure shut down switch 90 kPa Falling

Lubricating oil

Relief valve opening pressure 430 kPa
 Pressure at maximum speed 340 kPa
 Maximum continuous oil temperature (in rail) 125°C
 Oil consumption at full load (% of fuel) < 0.1

Recommended SAE viscosity

A multigrade oil must be used which conforms to API CH4 or CI4
 ACEA E5 must be used, see illustration below:

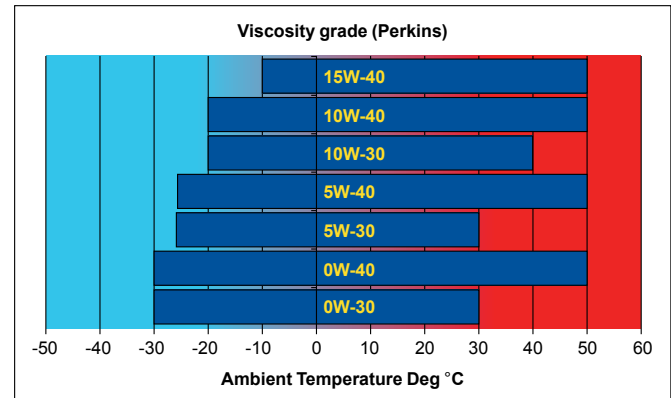

Mountings

Maximum static bending moment at rear face of block 1130 Nm
 Maximum permissible overhung load
 on the flywheel Calculated on request
 Maximum bending moment at rear of flywheel housing ± 3000 in Shock Nm

Load acceptance

The data below complies with the requirements of classification 3 and 4
 of ISO 8528-12 and G2 operating limits stated in ISO 8528-5.

Initial load application: When engine reaches rated speed (15
 seconds maximum after engine starts to crank).

Description	Units	1500 rpm	1800 rpm
% of prime power	%	95.0	93.5
Load	kWe	120.0	121.5
Transient frequency deviation	%	18.9	9.5
Frequency recovery time	Seconds	1.6	0.9

Noise data

Noise levels (predicted)

Prime power noise level dB(A)		
Position	50 Hz	60 Hz
F	95.6	99.8
R	95.6	99.3
L	95.4	99.0
A	92.9	96.2
FR	94.7	98.9
FL	94.9	98.9

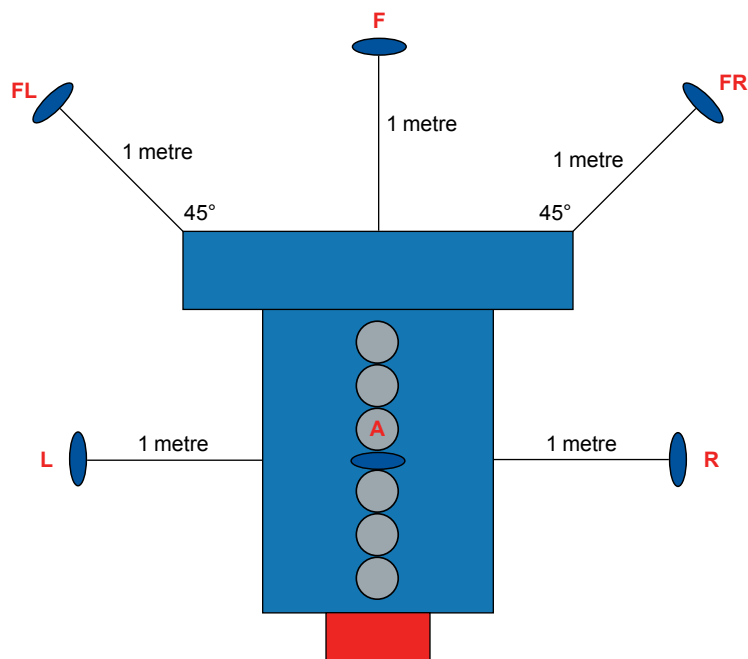

1106D-E70TAG2 - Left side view

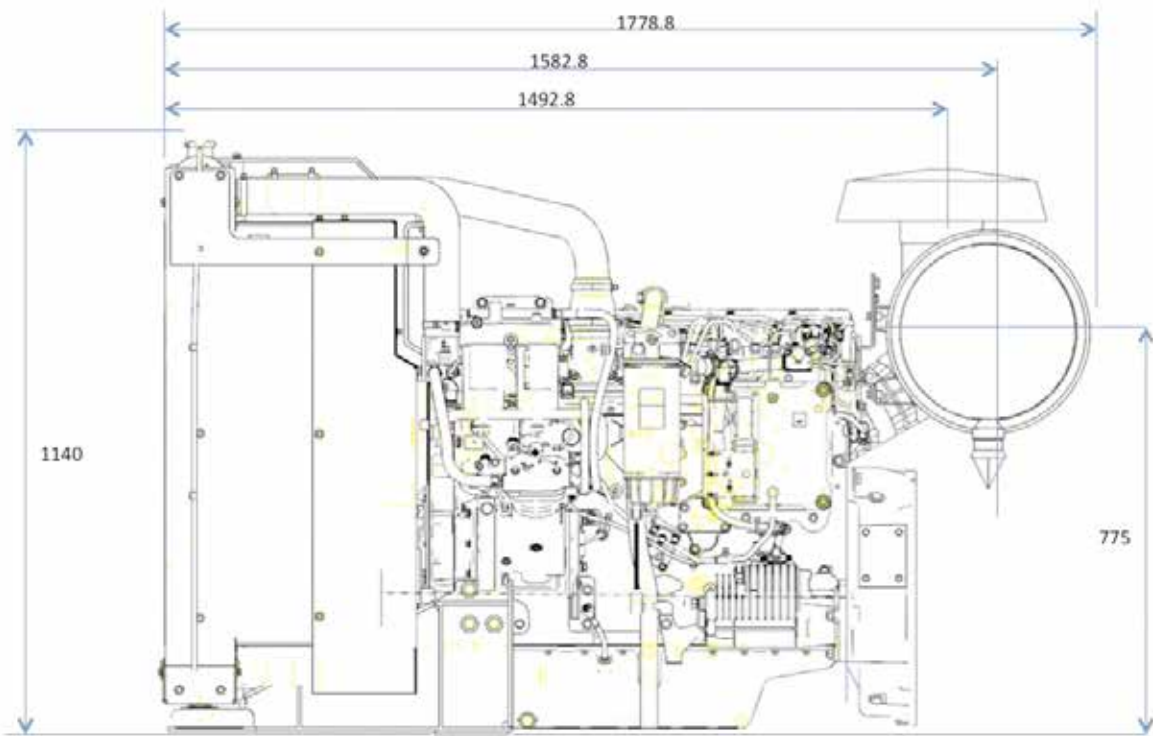

1106D-E70TAG2 - Front view

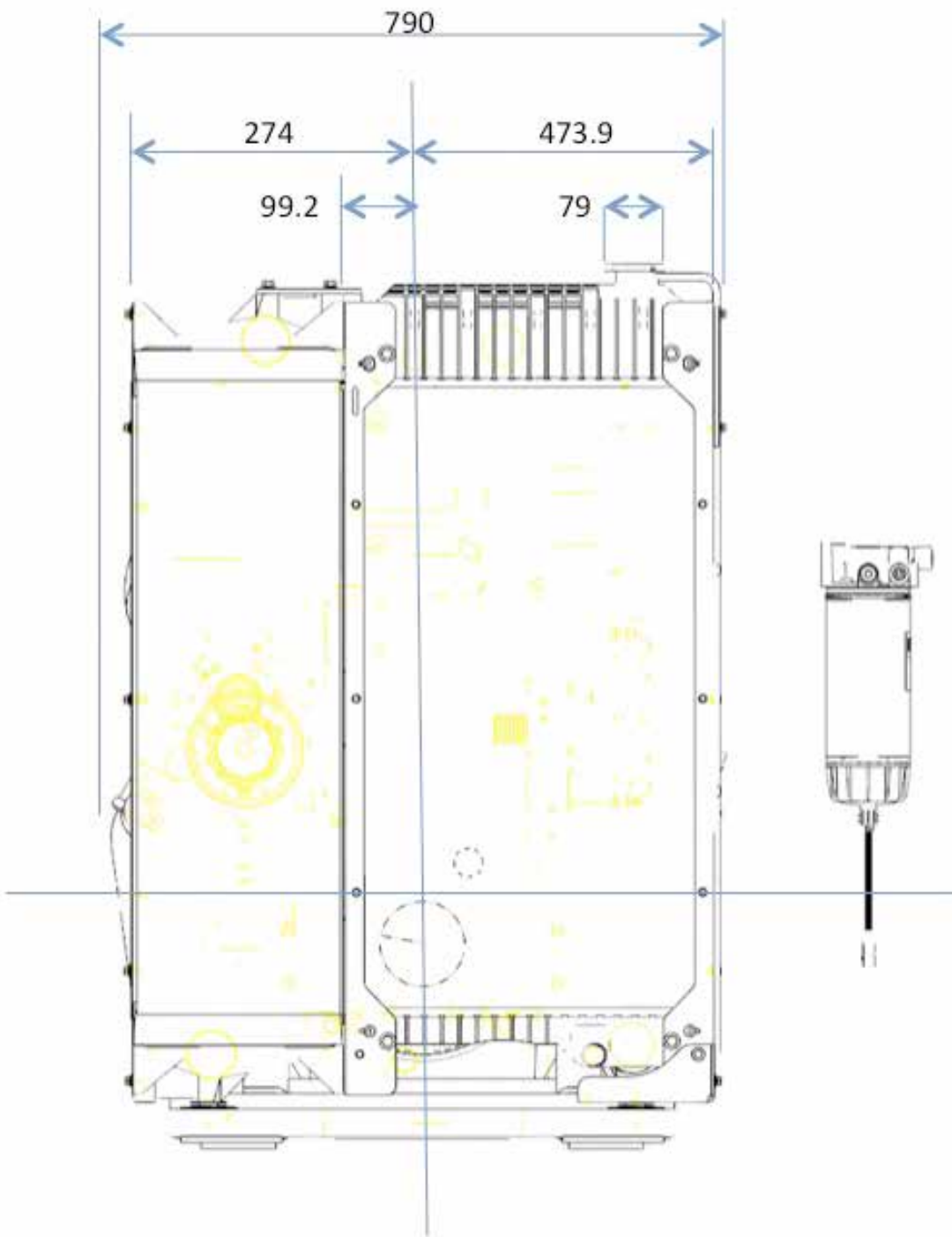

1106D-E70TAG2 - Right side view

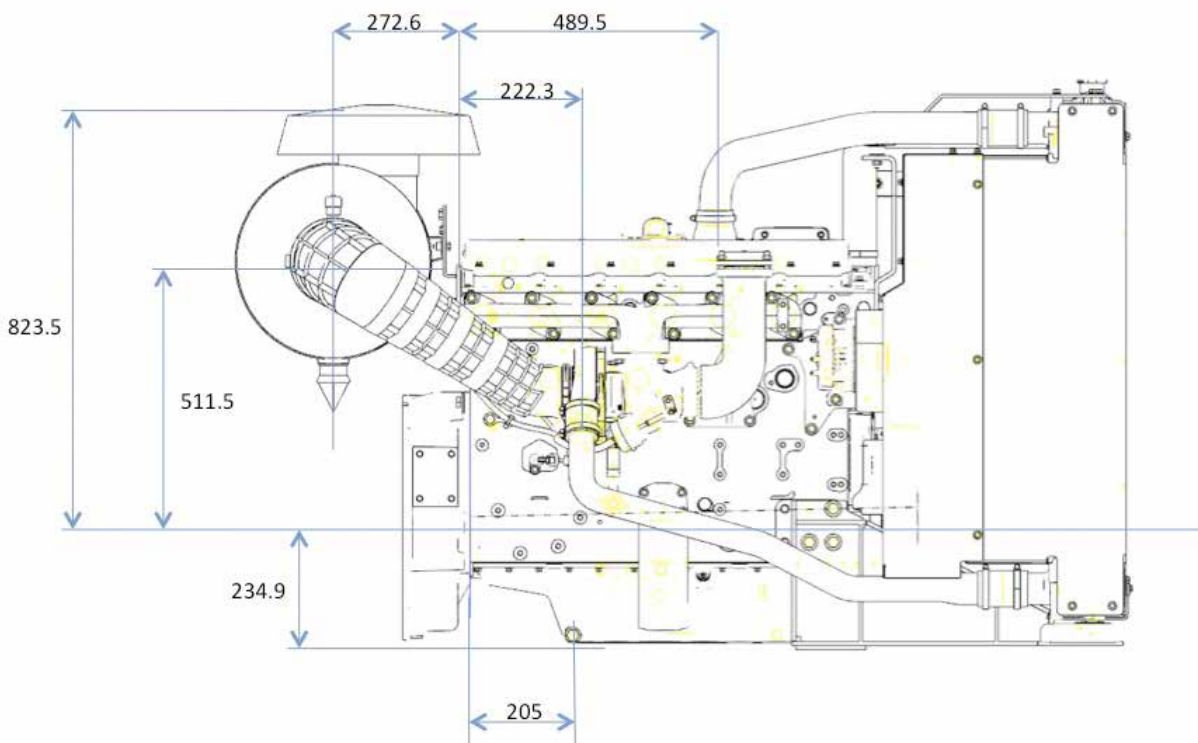

1106D-E70TAG2 - Rear view

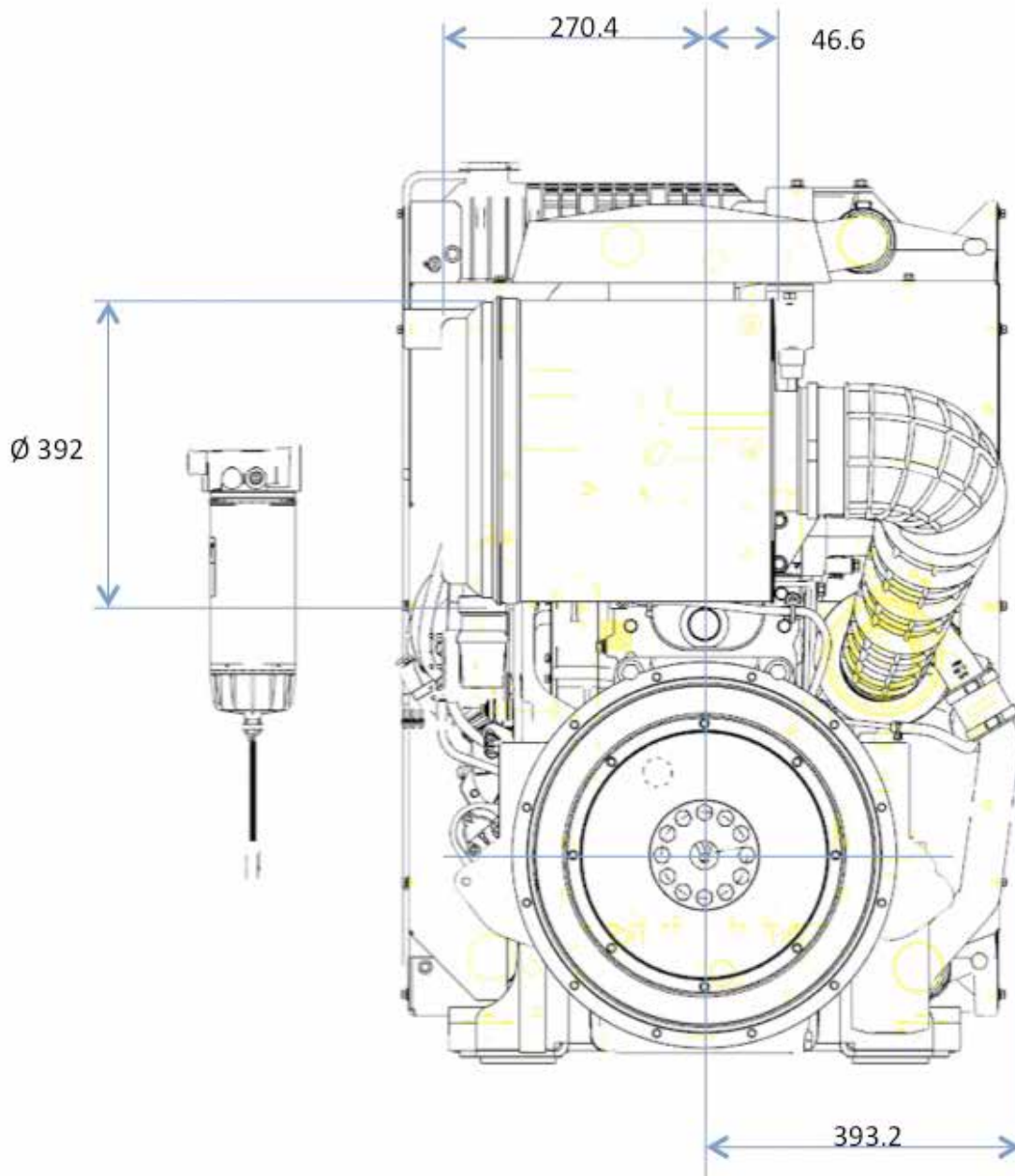

1106D-E70TAG2 - Plan view

