

# 404A-22G1

# 400

20.6 kWm @ 1500 rpm (Gross)

## Series

## ElectropaK

### Basic technical data

Number of cylinders	4
Cylinder arrangement	Vertical inline
Cycle	4 stroke
Induction system	Naturally aspirated
Compression ratio	23.3:1
Bore	84 mm
Stroke	100 mm
Cubic capacity	2.216 litres
Direction of rotation when viewed from flywheel	Anticlockwise
Firing order	1, 3, 4, 2

### Weight of ElectropaK

Dry	242 kg
-----	--------

### Overall dimensions of ElectropaK

Height	841 mm
Length (from rear of air cleaner to front face of radiator)	948 mm
Width (including mounting brackets)	498 mm

### Moments of inertia (mk<sup>2</sup>)

Engine rotational component	0.44 kgm <sup>2</sup>
Flywheel	2.55 kgm <sup>2</sup>

### Centre of gravity (engine only)

Forward from rear of block	147 mm
Above centre line of block	97 mm
Offset to RHS of centre line	3 mm

### Performance

**Note:** All data based on operation to ISO/TR14396 standard reference conditions.

Steady state speed stability at constant load  $\pm 0.75\%$

### Cyclic irregularity

At 110% standby power TBA

### Test conditions

Air temperature	25°C
Barometric pressure	100 kPa
Relative humidity	31.5%
Air inlet restriction at maximum power (nominal)	3.0 kPa
Exhaust back pressure at maximum power (nominal)	5.0 kPa
Fuel temperature (inlet pump)	50°C
All ratings certified to within	$\pm 5\%$ CRH

### Sound level

Average sound pressure level for bare engine (without inlet and exhaust) at 1 metre 76.4 dB(A)

### Notes:

- if the engine is to operate in ambient conditions other than those of the test conditions, suitable adjustments must be made for these changes. For full details, contact Perkins Technical Service Department

## General installation, 404A-22G1 @ 1500 rpm

Designation	Units	Type of operation and application	
		50 Hz	
		Prime	Standby
Gross engine power	kWb	18.7	20.6
Brake mean effective pressure	kPa	669	650
Mean piston speed	m/s	5	
Engine coolant flow (coolant pump ratio 1.33:1)	l/min	42.9	
Combustion air flow	m <sup>3</sup> /min	1.45	
Exhaust gas flow (maximum)	m <sup>3</sup> /min	3.64	3.94
Exhaust gas temperature outlet (maximum)	°C	445	505
Overall thermal efficiency (nett)	%	35	33
Typical genset electrical output (0.8 pf 25°C)	kWe	16.0	17.7
	kVA	20.0	22.1
Assumed alternator efficiency	%	87	

## Energy balance

Designation	Units	Type of operation and application	
		50 Hz	
		Prime	Standby
Energy in fuel (heat of combustion)	kWt	53.0	61.2
Energy in power output (gross)	kWb	18.7	20.6
Energy to cooling fan	kWt	0.3	
Energy in power output (nett)	kWm	18.4	20.3
Energy to coolant and lubricating oil	kWt	17.0	19.6
Energy to exhaust	kWt	14.0	16.6
Energy to radiation	kWt	3.3	4.4

**Caution:** The airflows shown in this table will provide acceptable cooling for an open power unit operating in ambient temperatures of up to 53°C (46°C with an airflow restriction of up to 80 Pa). If the power unit is to be enclosed totally, a cooling test must be done to check that the engine cooling is acceptable. If there is insufficient cooling, contact your Perkins Distributor or Perkins Technical Service Department.

## Cooling system

### Radiator

Radiator face area	0.167 m <sup>2</sup>
Number of rows and materials	2 rows, Aluminium,
Matrix density and material	14.5 fins/inch, Aluminium
Width of matrix	334.3 mm
Height of matrix	500.0 mm
Pressure cap setting	90 kPa
Estimated cooling air flow reserve	0.125 kPa

### Fan

Diameter	320 mm
Drive ratio	1.33:1
Number of blades	6
Material	Plastic
Type	Puller

### Coolant (total system capacity)

With radiator	7.0 litres
Without radiator	3.6 litres
Maximum top tank temperature	112°C
Temperature rise across engine	7.5°C
Maximum permissible external system resistance	15 kPa
Thermostat operation range	82 - 95°C

**Note:** Recommended coolant: 50% anti freeze/50% water.  
For complete details of recommended coolant specifications, refer to the Operation and Maintenance Manual for this engine model.

## Maximum static bending moment

At rear face of block ..... 1400 Nm

## Duct allowance

Maximum additional restriction (duct allowance) to cooling airflow and resultant minimum airflow		
Ambient clearance 50% Glycol	Duct allowance Pa	m <sup>3</sup> /sec
53°C	0	0.67
46°C	80	0.59

### Notes:

- thermal capability needs to be considered as a function of canopy design
- all data assumes 3°C air temperature rise over ambient into radiator

## Electrical system

Alternator	15 amps, 12 volts
Starter motor	2 kW, 12 volts

## Exhaust system

Maximum back pressure for total system	10.2 kPa
Inside diameter of outlet flange	42 mm

## Induction system

### Maximum air intake restriction

Clean filter	3.0 kPa
Dirty filter	6.4 kPa
Air filter type	Dry element type

## Cold start recommendations

Minimum cranking speed ..... 150 rev/min

Minimum starting temperature	Grade of engine lubricating oil	Battery specifications			
		BS3911 Cold start amps	SAEJ537 Cold cranking amps	Number of batteries required	Commercial reference number
0°C	20 W	540	740	1	647
-15°C	10 W	540	740	1	647
-20°C	5 W	600	780	1	655

**Note:** Additional information for battery and cable limits can be found in Chapter 6 of the 400 Engine Sales Manual.

## Fuel system

Type of injection .....	Indirect
Fuel injection pump .....	Cassette type
Fuel atomiser .....	Pintle nozzle
Nozzle opening pressure .....	14.7 MPa
Maximum particle size .....	25 microns

## Fuel lift pump

Type .....	mechanical (camshaft driven)
Flow/hour .....	63 litres/hour
Pressure .....	10 kPa
Maximum suction head .....	0.8 metre
Maximum static pressure head .....	3.0 metre
Governor type .....	Mechanical

## Fuel specification

USA Fed Off Highway .....	EPA2D 89.330-96
Europe Off Highway .....	CEC RF-06-99

**Note:** For further information on fuel specifications and restrictions, refer to the OMM Fuels section for this engine model.

## Fuel consumption

Power rating	1500 rpm	
	g/kWh	litres/hour
110%	244	6.1
100%	237	5.3
75%	238	4.0
50%	258	2.9

## Recommended SAE viscosity

A single or multigrade oil conforming to API-CH-4 or ACEA E5 must be used.

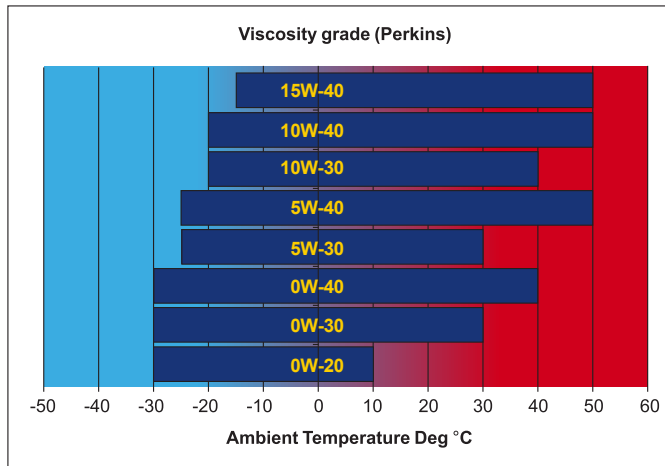

**Note:** For additional notes on lubricating oil specifications, refer to the Operation and Maintenance Manual

## Lubrication system

### Lubricating oil capacity

Maximum .....	10.6 litres
Minimum .....	8.9 litres
Maximum engine operating angles front up, front down, right side or left side .....	35° continuous

### Lubricating oil pressure

Relief valve opens .....	352 - 448kPa
Minimum oil pressure .....	120 kPa
At maximum no-load speed .....	TBA
Oil flow at rated speed .....	109 litres/min
Normal oil temperature .....	125°C

## Load acceptance

The below complies with the requirements of classification 3 and 4 of ISO 8528-12 and G2 operating limits stated in ISO 8528-5

Initial load application: When engine reaches rated speed (15 seconds maximum after engine starts to crank)		
Descriptor	Units	50 Hz
% of prime power	%	TBA
Transient frequency deviation	%	TBA
Frequency recovery	Seconds	TBA

The above figures were obtained under the following test conditions:

Minimum engine block temperature .....	TBA°C
Ambient temperature .....	25°C
Governing mode .....	5%
Alternator inertia .....	TBA kgm <sup>2</sup>
Under frequency roll off (UFRO) point set to .....	2% Volt/1% frequency
UFRO rate set to .....	1 Hz below rated speed
LAM on/off .....	off

**Note:** All tests were conducted using an engine which was installed and serviced to Perkins Engines Company Limited recommendations.

## Derate Curves

Derate curves for altitude and humidity can be found in Chapter 6 of the 400 Series Engine Sales Manual.

The general arrangement drawings shown in this data sheet are for guidance only. For installation purposes, latest versions should be requested from the Applications Department, Perkins Engines Stafford, ST16 3UB United Kingdom.

## 404A-22G1 ElectropaK - Left side view

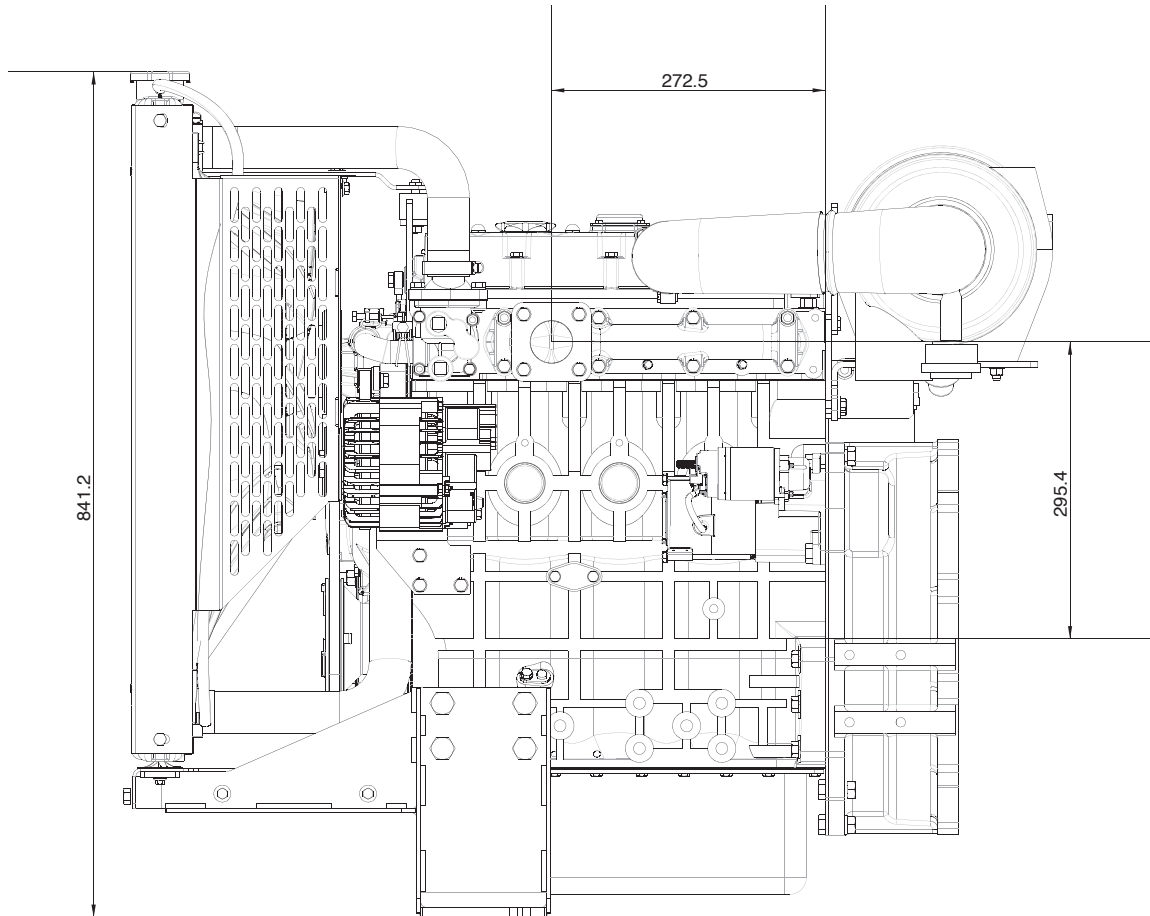

## 404A-22G1 Electropak - front view

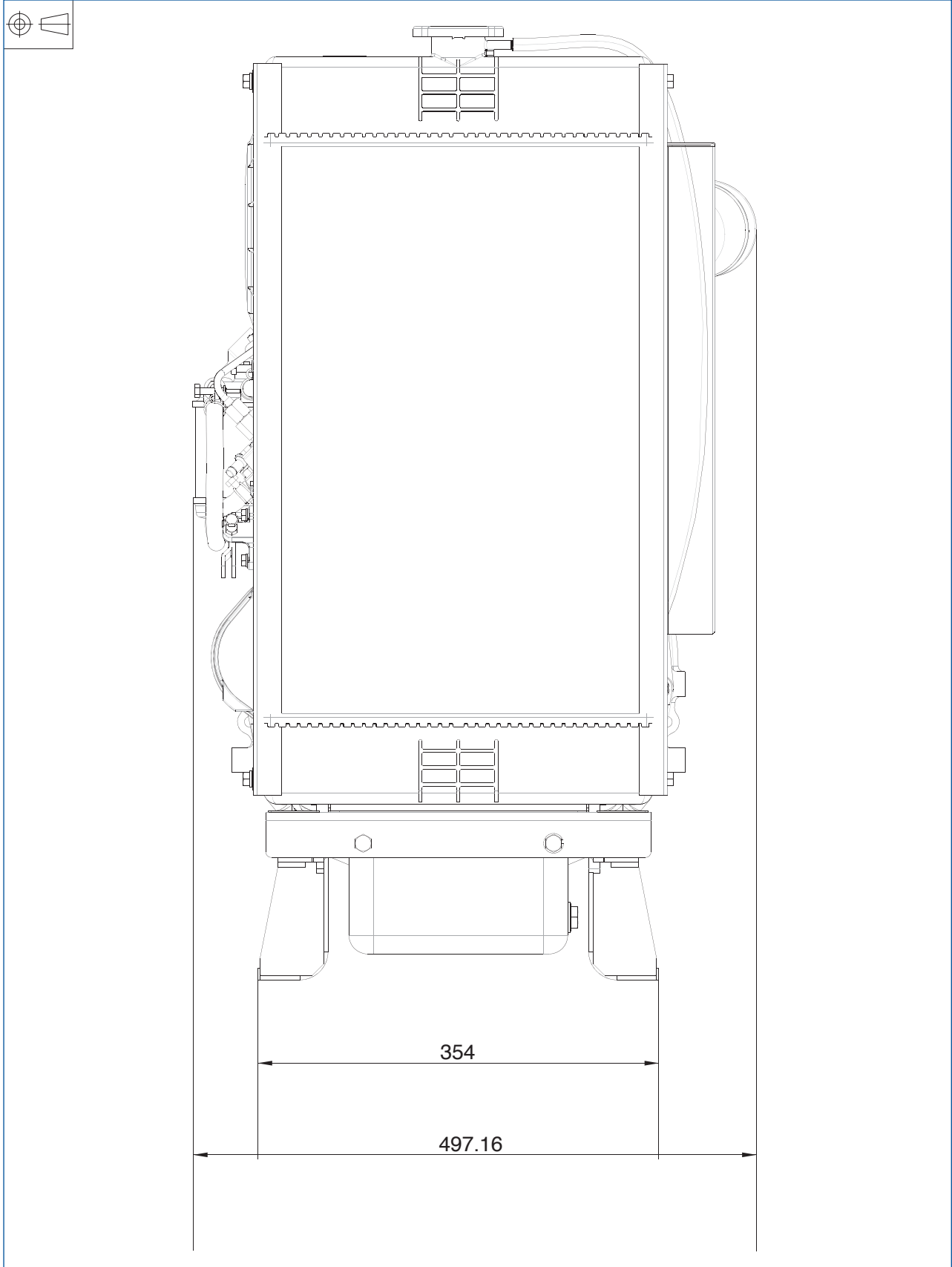

## 404A-22G1 Electropak - Right side view

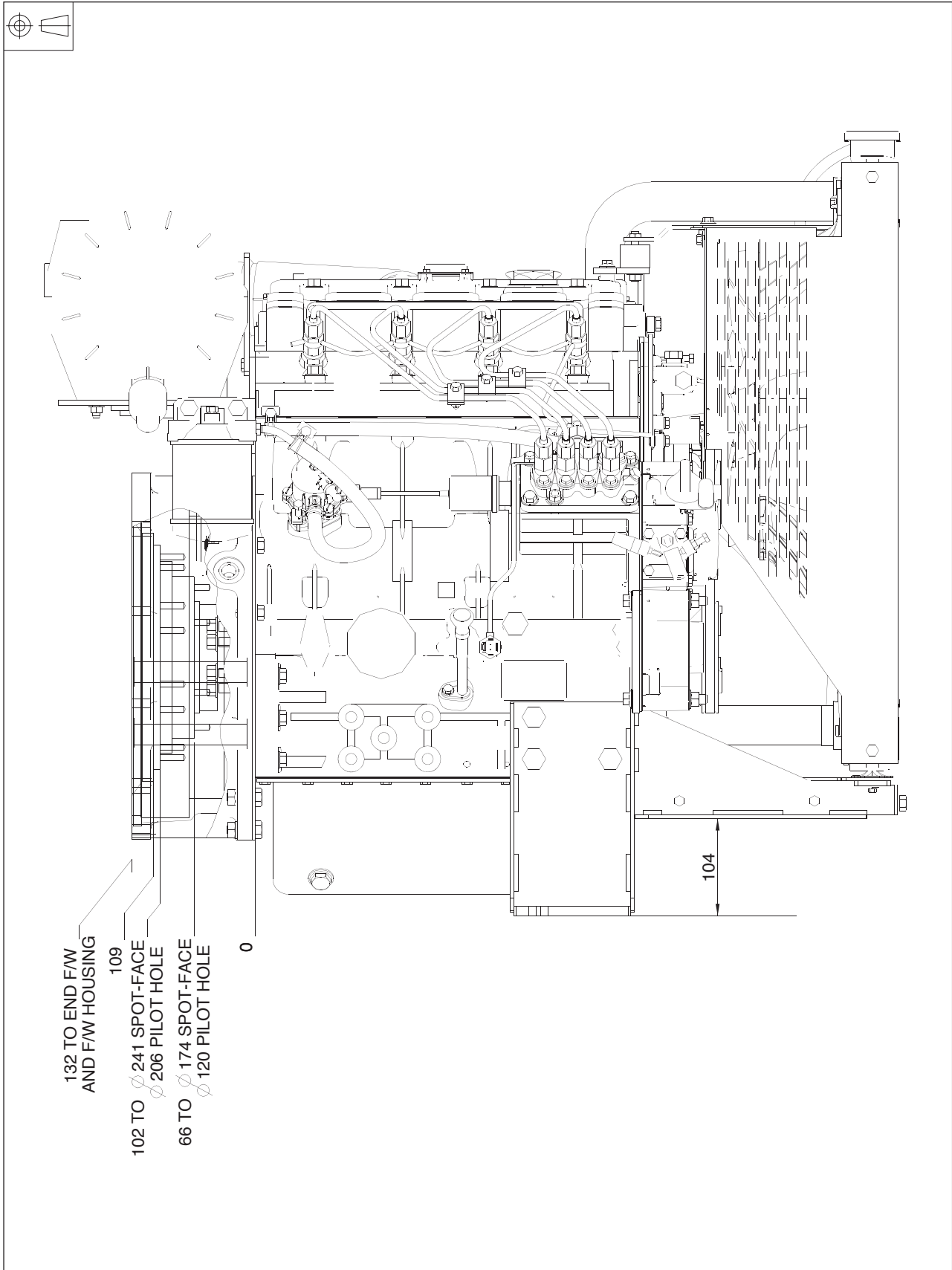

## 404A-22G1 Electropak - Rear view

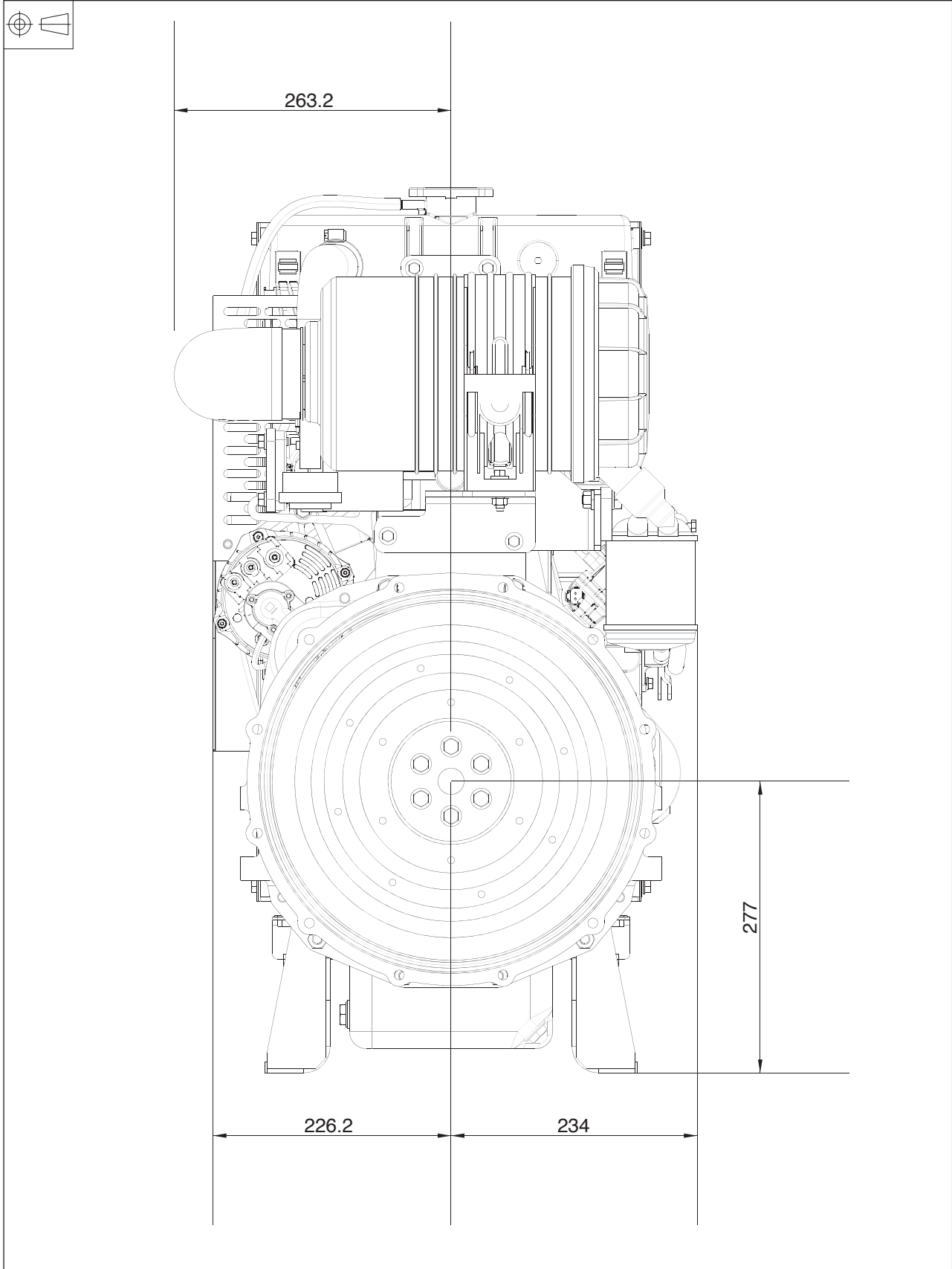



## 404A-22G1 Electropak - Plan view

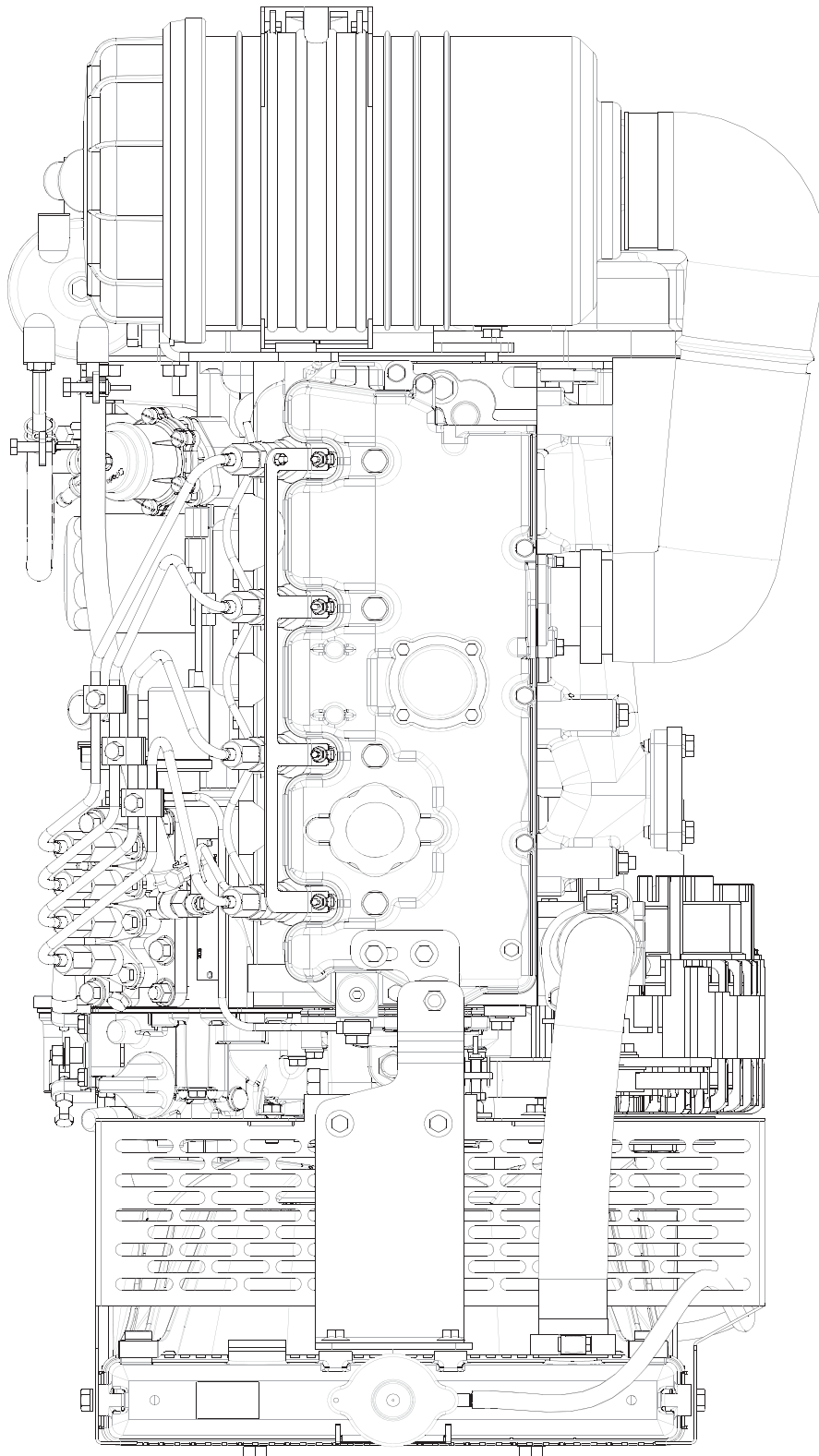

## 404A-22G1 ElectropaK - View from the bottom

